

ACEKOOL

Mixer MC3

INSTRUCTION MANUAL

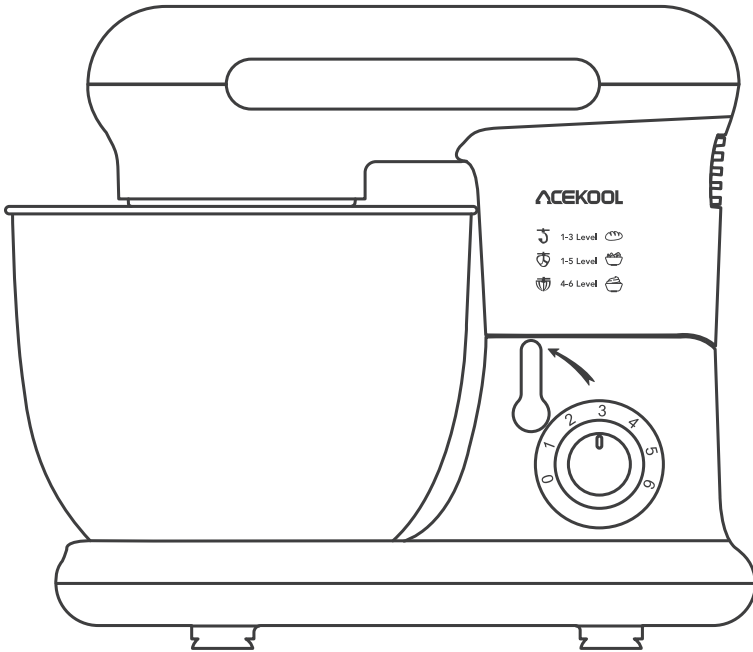

Thanks for your order. Please read the user manual thoroughly before using the product and keep this user manual for your future reference.

CONTENTS

■ Features	01
■ Important Safety Advice	02
■ Technical Data	04
■ Unpacking and setting up	04
■ Operation	04
■ Cleaning the appliance	08

Features

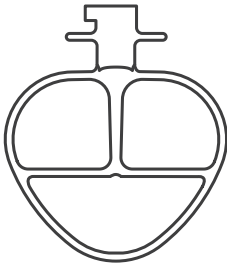
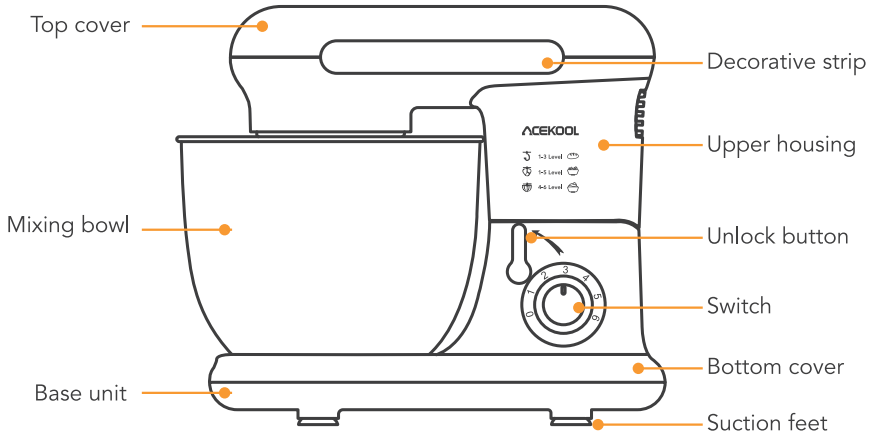

Mixing blade

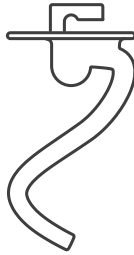

Dough hook

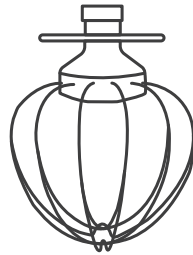

Egg whisk

Important Safety Advice

Please observe the following information to avoid injury or damage.

- The appliance may only be used by persons with reduced physical, sensory or mental capabilities or lacking experience and knowledge, if they have been given supervision or instruction concerning the use of the appliance and fully understand all dangers and safety precautions involved.
- Children are forbidden to operate the equipment. Keep this product and its power cord away from children.
- The appliance can not be operated with an external timer or separate remote control system such as a remote control socket.
- Always remove the power supply plug from the mains socket before starting to clean the appliance.
- Do not immerse base unit in water.
- Do not use abrasive, corrosive or scratching cleaning materials. They could damage the appliance.
- To prevent damage, check that the mains voltage required is compatible with your mains voltage.
- Only use one attachment at a time!
- Make sure it is disconnected from the power supply and has cooled down completely before cleaning the appliance.
- The appliance must not under any circumstances be used if it is damaged. Have the device repaired in such cases by a qualified specialist.
- If the mains cable for this appliance is damaged, it must be replaced by the manufacturer or a person with similar qualifications in order to avoid a hazard.
- Under no circumstances should water or other liquids get into the base unit. For this reason, Never use it outdoors; Never immerse the base unit in water; Never place containers filled with liquid, such as drinking glasses, vases etc. on the appliance; Never use in very humid environments; Never use in the immediate vicinity of a kitchen sink, bath, shower or a swimming pool, as water may splash into the appliance; If liquid should enter the appliance, unplug the mains plug immediately and have the appliance repaired by a qualified technician.
- Never touch the appliance, the mains cable or the mains plug with wet hands.
- Always unplug it by pulling out the plug, never pull on the cable itself.
- Ensure that the mains cable is not kinked, twisted or crushed.
- Keep the mains cable away from hot surfaces, such as the top of a stove.
- If you are not going to use the appliance for a while, remove the plug from the wall socket. Only then is the appliance completely free of current.
- This appliance is not intended for use by persons (including children) with reduced physical, sensory or mental capabilities or lack of experience and knowledge, unless they are closely supervised and instructed concerning use of the appliance by a person responsible for their safety. Close supervision is necessary when any appliance is used by or near children. Children should be supervised to ensure that they do not play with the appliance.

- Do not operate any appliance with a damaged cord or plug or after the appliance malfunctions or is dropped or damaged in any manner.
- The use of attachments not recommended or sold by the manufacturer may cause fire, electric shock or injury.
- Do not let cord hang over edge of table or counter.
- Keep hands, hair, clothing, as well as spatulas and other utensils away from beaters during operation to reduce the risk of injury to persons or damage to the mixer.
- Remove beaters from mixer before washing.
- Turn the appliance OFF, then unplug from the outlet when not in use, before assembling or disassembling parts and before cleaning.
- To unplug, grasp the plug and pull from the outlet. Never pull from the power cord. Permanently Installed-Make sure appliance is OFF when not in use, before putting on or taking off parts and before cleaning.
- Make sure that the mains cable never becomes a trip hazard, that no one can get tangled in it or tread on it.
- During operation, avoid contact with the moving parts of the appliance such as the dough hook, balloon whisk or beater. Your hands or hair could be drawn into the appliance, leading to injuries. Only ever switch the appliance on if you have correctly fitted the splash guard when using the mixing bowl.
- Always remove the plug from the wall socket: when there is no supervision, after each cycle of use, in case of any malfunction, before cleaning, assembling or disassembling the appliance, Before changing any attachment.
- This appliance is intended for domestic or similar applications, such as, by staff members in shops, offices and other similar working environments, in agricultural working environments, by customers in hotels, motels etc. and similar establishments, in bed-and breakfast type environments.
- This appliance has important markings on the plug blade. The attachment plug or entire cord set (if plug is molded onto cord) is not suitable for replacement. If damaged, the appliance shall be replaced.
- This appliance has a polarized plug (one blade is wider than the other). To reduce the risk of electric shock, this plug will fit in a polarized outlet only one way. If the plug does not fit fully in the outlet, reverse the plug. If it still does not fit, contact a qualified electrician. Do not modify the plug in any way.
- Only place the appliance on a level, dry, non-slip surface to stop the appliance falling over or sliding off.
- Do not place the appliance on top of a hot stove.
- Never use the mixer when empty. This might cause the motor to overheat.
- Do not move the appliance if food or pastry is still inside.
- Do not overfill the mixing bowl as the contents might otherwise be ejected.
- The appliance has been designed for short-term operation only, it should not be operated continuously for more than 4 minutes. Switch off the appliance afterwards and allow the motor to cool down before switching it on again.
- Make sure that the supply voltage corresponds with the voltage marked on the rating label. This product complies with all binding UL labeling directives.

Technical Data

Nominal voltage: 120V, 60Hz Power consumption: 300W MAX
Max. capacity (Mixing bowl): 4 Quart

Unpacking and setting up

- Unpack the appliance from the packaging, Remove the transport packaging.
- Check that the appliance shows no signs of damage.
- Place the appliance on a level, dry, nonslip surface so that the appliance can neither fall over nor slide off.
- Check that the speed controller is set to "0".
- Put the plug in a suitable socket, The appliance is now ready to use.

Operation

Assembling the appliance

- Put up the unlock lever and swing up the drive arm.

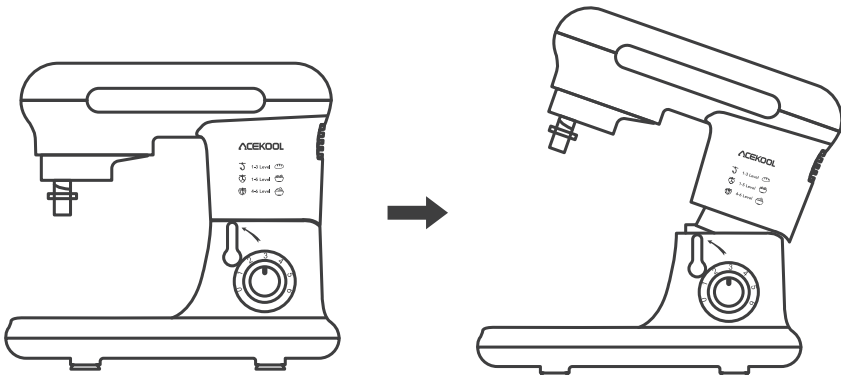

- To fit the mixing bowl, insert it in the base unit.
- Lock the mixing bowl by rotating it slightly clockwise until it engages.

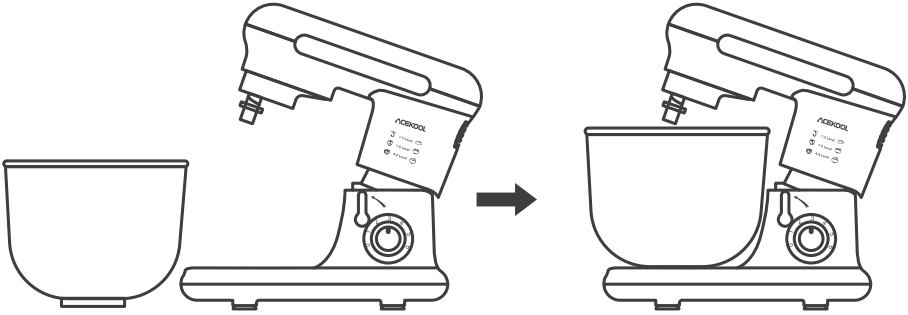

- **Select the appropriate attachment:**

Dough hook: For heavy dough, e.g. bread dough

Balloon whisk: For whipping cream, beating egg whites, etc.

Beater: For medium to light dough / batter, e.g. batter for (pan) cakes.

- Fit the attachment into the appropriate opening in the drive arm from below, When doing so, make sure that the little lugs on the shaft of the attachment are inserted into the crosswise slot of the opening.

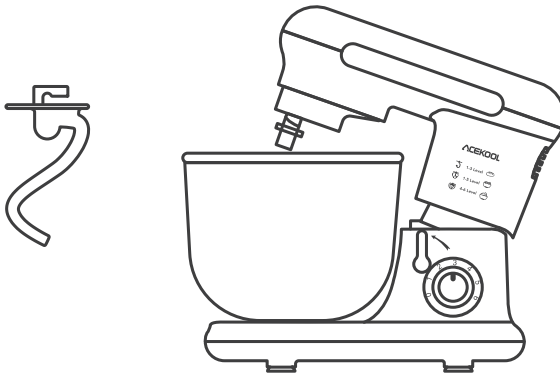

- Press the attachment lightly in and turn anti-clockwise until it engages.
- Press the unlock lever and swing the drive arm down into the working position, The appliance is now ready to use.

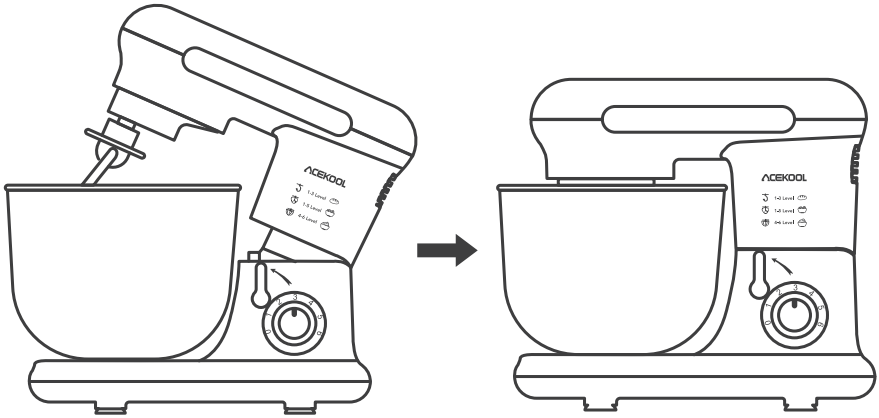

Dismantle appliance

- Press the unlock lever and swing up the drive arm.
- To remove an attachment, press lightly in again and unlock by turning clockwise slightly.
- Remove the attachment.
- Unlock the mixing bowl by rotating slightly in a anti-clockwise direction.
- Remove the mixing bowl.
- Press the unlock lever and swing the drive arm down into the working position.

Regulating speed, switching on and off

- Switch the appliance on by turning the speed controller to the right.
- Start off at a slightly slower speed when mixing and then increase.

Recommendations for speed levels

Speed	Attachment	Description
1-3	Dough hook	<ul style="list-style-type: none"> ● Starting position for all mixing operations. ● When adding ingredients. ● Kneading and mixing firm dough or ingredients. <p>Ingredients</p> <ul style="list-style-type: none"> ● 0.4 kg plain flour ● 0.22kg lukewarm water <p>Preparation</p> <ul style="list-style-type: none"> ● Put the ingredients in the mixing bowl. ● Fit the splash guard and dough hook. ● Speed: 1st, knead for 30s on level 1. 2nd, knead for 30s on level 2. 3rd, knead for 3 minutes on level 3.
4-6 / Pulse button	Balloon whisk	<ul style="list-style-type: none"> ● Whipping cream ● Egg whites ● Mayonnaise ● Beating butter until fluffy <p>Ingredients</p> <ul style="list-style-type: none"> ● 6 egg whites <p>Preparation</p> <ul style="list-style-type: none"> ● Put the egg whites in the mixing bowl. ● Fit the splash guard and the balloon whisk. ● Beat the egg whites at level 6 for 4 minutes until stiff.

Cleaning the appliance

To prevent the risk of electric shock, injury or damage:

- Disconnect the power supply plug from the mains socket before cleaning.
- Never immerse the base unit in water.
- Never use scouring, corrosive or abrasive cleaning materials as these could damage the appliance.

Cleaning the base unit

- Clean the base unit with a damp cloth. A little detergent may also be used.
- Wipe over with clean water.
- Do not use the base unit again until it is completely dry.

Cleaning dough hook, balloon whisk and beater

- The dough hook, balloon whisk and beater can be washed in the dishwasher.
- Put the parts in cold or lukewarm water to soften dough residues. Note, You can also add a little detergent to the water.
- Remove softened dough residues with a washing-up brush.
- Rinse off with clean water.
- Allow parts to dry completely before using them again.

Cleaning the mixing bowl

The mixing bowl is made of stainless steel and can be cleaned in the sink or dishwasher.



At the end of its service life, this product may not be disposed of in the normal household waste, but rather must be disposed of at a collection point for recycling electrical and electronic devices. The materials are recyclable according to their labelling. You make an important contribution to protecting our environment by reusing, recycling or utilising old devices in other ways. Please ask the municipal administration where the appropriate disposal facility is located.

ACEKOOOL

— Make Life Easier —

Model: SM-C01

Email: support@acekool.vip

Website: <https://www.acekool.vip>

Made in China

